

Stability of Grid With The Penetration of Solar PV Based Generation In Power Plant

Prof. Hugar Niranjana Shivasharanappa, Prof. Rawale Pournima Pradip, Prof. Meenu Jeemon v n jeemon, Prof. Gupta Ankit Anil, Prof. Katyarmal Pooja.

Dattakala Shikshan Sanstha “Dattakala Group of Institution” Swami-Chincholi, Daund, Pune, Maharashtra 413130. India.

Abstract-This is a well-known fact that the world is facing climatic risk from the emission of power generating plants. Thermal power plant is causing mercury pollution which is very dangerous to human health as it affects the neural system. In light of such ugly facts now all the developed countries are changing their focus on renewable source of energy for sustainable and emission free power. we are considerably High PV dispersion levels can occupy the steady state and the transient stability of the systems outstanding to their various description. that differ from conventional generation property. We are consider an important amount of conservative generation With high PV generation may be replaced with increase PV property. A much needed renewable source with zero emission has got sufficiently large possible of energy which can be harness by using a number of devices available. Synchronized manage of the included power system is fruitfully done with the THD mechanism within universal of parameters.

Keywords-Integration of Grid, PV Cells, PV Module, Array, Boost Converter, Fuzzy Logic, Harmonics Analysis.

I. INTRODUCTION

This is a well-known fact that the world is facing climatic hazard from the emission of power generating plants in large scale. Thermal power plant is causing mercury pollution which is very dangerous to human life as it affects the neural system. It effect the Child born with mental disability is one of its potent ill impacts on the human society. In light of such ugly facts now all the developed countries are shifting their focus on renewable source of energy for sustainable and emission free power to connect the nature.

The ultimate source of energy of course solar energy is in prime focus as the global climatic changes are alarming. The process of harvesting solar energy is the quite very simple. The solar irradiation is the collected through the solar panel/collector and converted into useful electric energy. Solar energy is most potent alternate available in present scenario to the mankind. As we know that much of needed renewable source with zero the emission has got adequately large potential of energy which can be harnessed by providing a number of devices to be available. With the advancement of the technology industrial sector and house hold requirement of energy can be easily mitigated with less maintenance.

To promote in very large scale the renewable generation of power the government is providing rebates and subsidies in light of the Clean Development Mechanism (CDM).

1. **The Environmental of constrain leading to the need of renewable energy:**

Exhausting stock of non-renewable energy recourse with its ill impact on the climatic condition mankind hasn't left with much choice other than Renewable energy. In present day The Global warming is the most severe threat present. Due to global warming the ice is melting leading to rise in the sea level causing many cities under threat of submerge.

2. **Meaning of renewable energy :**

2.1 Project of small Hydropower: With rating up to 10MW of installation hydropower plant is considered as small hydropower plant and renewable source of energy. In this hydropower plant has to capability that to convert the same most important power plant potential energy has to be transformed into the kinetic energy of water and than valuable electricity. Water turbine is used for the purpose of conversion of potential energy of water into useful electricity. Small project involve in the running water of river uses the kinetic energy of the water the without the complexity of construction of dams.

2.2 Project of wind power: As we know the name advice energy of the air flow that generates the electricity is generated through the kinetic. Presently wind turbine of rating 600KW to 5MW range is available in the market. Non-linear relation between the power and speed of turbine results in the sudden change of output of load with the fluctuation of wind speed. Recent day trends advancement in the technologies develops better wind turbine design in the shape of better wing. Such smart design turbine has better performance due to the aerodynamic structure.

2.3 Project of Biomass: The energy captured by the sun in the process of photosynthesis is used in the biomass project for the generation of electricity. Biomass works as a natural battery for the storage of sun energy.

2.4 Project of Geothermal energy: Power generation are to be generated from Energy stored in the layers of earth. Major challenge is associated with this project is its location which is near the tectonic plate boundaries. The advancement in the technologies are trying to overcome it's constrain associated with the location. The superheated steam has to be creating by incline based geothermal energy. This superheated steam additional may be used to run the turbine and generate electricity.

2.5 Project of solar power: It is the most practical source of energy mankind left with. Its energy can be second- hand by mankind in two conducts.

- Method is in the figure of solar to thermal energy
- Method the translation of solar irradiation into the working electrical energy. Solar energy produce is mostly performed by second method today.

3. **Integration Gride of recourses:**

After knowing all the possible source of renewable energy now we are left with the challenge of apopte integration of renewable energy source with the alive conventional power plants. We have to select the arrangement of renewable energy according to the possibility of avaliability.

The major restrain connected with the renewable energyfrom source is its geographical location. Wind power project, small hydropower project, Geo thermal power project and the all the above

mentioned power plant have possession of their own constrain of geographical location. Only coastal areas are best suited for wind power plant as the progress of wind through out the year is good sufficient to run the wind power plant.

Desert area with better solar irradiation will serve better purpose of the solar power plant rather than any other location. This is the cause why china spain and USA are leading country in solar power generation.China is the country with highest rating of solar power plant generation rating of the 850 MW.For operation of Geothermal power plants need sea bed basically. Renewable source cannot be included against its practicable geographical location.

On the basis of demand of nature the power generation plants can be categorised into two types:

3.1 Base load power plant: These are the power plant that can generate consistent power supply to get together the basic requirement of electricity prevailing 24 hours. Ex. Thermal power plants and nuclear power plants are most excellent suitable for this intention of work. Once these power plants are started they run continuously without sever only in case of repairing work such plants are not working.

3.2 Peak load power plant: These plants are operational only when the demand goes higher than the normal demand. The electricity is costlier than the normal load. Such power plant operates only in co-ordination with the base power plants. Pump storage hydroelectric power plant are used for the peak load power plant.

4. Outline & Objective of project:

- Chapter 1 contains the introduction of the project. Requirements of such systems, possibility, options and constrains are discussed.
- Chapter 2 contains Literature review and related overview about the project with critical analysis of literature review.
- Chapter 3 contains Modelling and description of components with mathematical analysis of system characteristic. PV array, Boost converter and its working and the modelling of diesel generator are discussed.
- Chapter 4 contains overview of Fuzzy logic & PQ control method. History, basic concepts, membership function and rule based inference are to be discussed.
- Chapter 5 contains the simulation, results and analysis of results.
- Chapter 6 contains conclusion. References are listed in the end.

A model of grid with high diffusion of PV module is considered for this project work. Movement of integrating renewable source of power with conventional power system is increasing day by day. The conventional diesel generator along with the PV module is unnatural in co- ordination with P-Q method and Fuzzy logic. Base load generation is done by diesel engine. The power output of PV module is greater than before with the help of boost converter. Filter is used to reduce THD component. The generators are connected through the breakers with specified timing of switching for grid integration. Specified timing will help in the analysis of collision of the

switching on and off of base load generator with higher penetration of PV generation of the grid.

The objective of this project is to performance of co-ordinated control of P-Q method and fuzzy logic method for the better control of power system parameters. Fuzzy logic exhibit its own inherited characteristic features that improves the controlling process.

As mentioned in this topic earlier this system has higher penetration of PV generation. The ill impact due to sudden on and off base load generator on the stability of power system is analysed. Co-ordinated control of P-Q method and Fuzzy logic control method is applied for quicker operation of control system.

II. LITERATURE REVIEW & CONTEXTUAL OVERVIEW

Most of purpose of an academic research paper is to articulate and document an unique idea. Literature Review and background overview is one part of that process of writing a research paper. In a research paper, you use the literature as a initial point, a building block and as confirmation of a new nearby. The goal of the literature review is only to sum up and create the arguments and ideas of others. It is not to be a synthesised forum for the original idea. It has been seen to be very fast manner to be collaborated of very large to be synthesised of very large manner

In the recent situation the establishment of major power generating station is not matching the demand of power consumption. Therefore the integration of small power plant is in universal practice today. Different methodologies are being adopted for the better control of power system stability. P-Q control and V-F control are already been used in synchronisation with the satisfactory results. Various works that has been done in the fresh past is discussed in this chapter 2.

1. Previous works:

Mosobi, Toko Chichi and Sarsing Gao focus on the breakdown of power quality of the integrated renewable energy system. The main aim of this paper was to supply electrical energy to the community residing in rural or far from the grid supply. In this paper main focus was on the solar system, a micro hydro system and a wind energy system to work in integrated manner for the supply of the load. With the photovoltaic system most commonly used the maximum power point tracking system is applied in order to achieve reliable supply of power output.

While in the Wind energy system a variable speed wind- turbine set with fixed field angle is used which drives a capacitor excited asynchronous generator. The modelling of capacitor excited the asynchronous generator was done with a close loop turbine input system so that drooping quality can be accounted. Micro hydro systems consist of a excited asynchronous generator with constant power capacitor.

All three different sources are then connected to the main grid bus after that the presentation of the system is analysed under the varying load.

Quality of power supplied through this integrated system need to be better reason being harmonics present in the system. This is why power conditioning is employed in the system a boost converter in MPPT and a three phase current control inverter using IGBT along with the LC filter. They were able to successfully integrate the all three system with proper power quality control with the maintained voltage level under load condition. With the connection of load the THD of system minimised upto the encouraging level of 0.04-0.05% for R and RL loads respectively.

A paper [2] by **Huijuan Li, Yan Xu and their team** were able to control both real and reactive power interfacing of power electronic device with the photovoltaic system with sufficient algorithms. In this paper they offered the plan of organize algorithms for three phase single stage grid associated PV inverter to achieve either real power booster or reactive power control. They encounter the challenge of control design without DC-DC booster period while the PV inverter was working at the maximum power point with reactive power control. In this paper discussion on PV DC voltage give way phenomenon and its reason are discussed as well. To make sure the voltage stability method based on powerful improvement were projected for PV inverter output.

AliBidram and his team have functioning on the micro grids for adaptive and circulated secondary voltage control. The system on which they were working was distributed generation of system. They used the capability of Neural Network to recompense the doubts that arise due to the unknown dynamics of DGs. The magnificence of their planned method is the use of light communication network for their secondary control. They have calculated their control structure fully distributed in such a way that each DG requires its own in sequence with the information of its neighbour near on the network. Considering the fact that the future requirement compensation is possible by general installation of micro grid the analysis done in this paper has great significance. They have analyse the effectiveness of the propose method for various loading in case of outage condition as well as for the islanding scenarios. Variable communication structure of the micro grid setup is also analysed in this paper.

Mr. Chaitanya J. Kadam and his team analysed the performance of a single phase multistring five level inverter with grid connection. The arrangements of PVA. string is made such a way (parallel) that it will produce five levels. They use of filter of smaller size Use of higher level of inverters allows. They found out this is not the only advantage connected with this arrangement along with improved waveform there was remarkable reduction in the THD component. The electromagnetic interfering of the system minimises to the understand level. Even the forecasting of load is not much near to the actual future requirement due to surprising projects. So there should be arrangement of expansion with ease and this system analysis does faithfully same as the expansion is easier. Only one auxiliary circuit is enough for the expansion leading to the compact size of hardware and cost.

Ranjan K. Behera work refers the direct problem related with the utility is analysed and tried to meet the required ambition of a good power quality. When the integrated system is significant in

the rating of the grid the grid is considered as weak grid as is not remain a strong bumper for voltage profile. They have simulated the grid tie inverter and try to improve the basic parameters as power factor power quality and proper injection of DC current into the grid. Even when all the parameters are evaluated correctly and properly connections are made there must be grid synchronisation in order to have a stable operation of the power system.

Their work considered the grid phase and frequency as the reference template. They have done general experimental group for their investigation. After installation of PV panel Converter and inverter along with filter are to be arranged. When the nonlinear loads are connected with the system they found alteration in the wave form. Although operation near to full loads condition shows lesser THD component while process near lightly loaded condition confirmsthe high THD component.

Nattapal Sa-ngawang and his team were able to control the load frequency without down time in defuzzification. Although the work was done in the practical scenario of three-area loop which was interconnected in a power system approves the greater performance with system frequency also supply power near to the maximum power point during its control. they found that the control effect of PV with SFLC is better With varying load condition. The control of AC power output of PV inverter has been fast. The purpose of SFLC smart control in PV system was satisfactorily implemented and analysed.

A paper by **Manish kumar, mantukumar, Atsushi suxcena** focus on the control of frequency of the megawatt class of PV generation with the help of fuzzy. Due to the high PV penetration the instability in the frequency of the system arises. With the help of co-ordinated inverter and following battery control method they successfully controlled the frequency for various insulations.

The Rangy Sunny PG Scholar along with his team analysed the harmonic component associated with the PV output. The toll they used for this purpose is fuzzy only. They implemented fuzzy with hysteresis current control as frequency controller. They have used triangular membership function with 49 rules. Lately an arithmetic branch of learning constructed convagueness as well as uncertainty, fuzzy logic control (FLC), permits to utilize imprecise or unclear concepts. in addition FLC has the powerful performance under load instability

From the time when Mamdani issued his practices utilizing a FLC on a test-bed plant in a test centre, numerous control methodologies, as well as applications of FLC, have existed in the literature.

In addition, the fundamental benefit of the FLC over the conventional controller is that it is not as much of reliant on the mathematical model, as well as scheme parameters as acknowledge based. Thus, the FLC is convenient for inverter control process [11].

Although the results were hopeful but the feasibility of the system with wind power system and the micro hydro system is not possible at much location in India

- For large sudden disturbance the speed of the PI controller with fixed gain may not be fast enough to avoid the DC voltage collapse
- To overcome these shortcomings efforts has been made in this project.

2. Overview of project :

In this project integration of solar power plant with its high penetration is done along with the diesel power plant to the connected to the grid. Here the diesel power plant is serving as the base load/peak load as per requirement of power generating plant. The analysis of power plant in to isolate condition and the integrated situation is done.

While the connecting the diesel power generator and grid integration with PV power generating system impact on the voltage wave form is observed and analysed. Integration of power plant although gives the suitable output in term of voltage waveform but high harmonic components is watch in the output. An inductor as clean is added in the imitation model. The value of the inductor is chosen such as the value of the THD section lies within the standard limits.

III. MODELLING AND DESCRIPTION OF COMPONENTS

The increasing interest for renewable energies and combine is due to the world principles of revising the energy policies, in order to fight against the emissions of CO₂. Some proposal to achieve this goal is: substitute the remnant fuels for cleaner energies, limit the damages in the environment and in the ecosystem, as well as incentive to develop alternative resources.

The photovoltaic energy is a hygienic energy, with a long ordinary life and a high dependability. So, it can be considered as one of the most sustainable of the renewable energies. These systems can be located in or near where the necessity takes place, avoiding losses of transmission and contributing reductions to the CO₂ emission in urban centers.

The photovoltaic unit is the result of associate a group of photovoltaic cells in series and parallel with their resistance devices, and it represents the conversion unit in this generation system. Besides, the obtained energy depends on the solar radiation, the temperature of the cell Photovoltaic cell:

This is the basic structural unit of solar panel which converts the solar radiation of sun into the usable form of electric energy by virtue of the photovoltaic effect. The concept of energy band gap and the energy of photons account for the phenomenon of photovoltaic effect.

If the energy of photon exceeds the energy of band gap the discharge of electrons from their individual orbital took place resulting in the flow of current in the outside circuit.

1. PV module:

It is the structural agreement of cells according to the condition of the energy. Even their availability in the for profit market is categorised according to their power generation capacity as of 60W to 170W.

2. PV array:

It has larger arrangement of PV cells during the relationship either in parallel / series. These two methods of relationship are implement according to the condition of the output. Parallel combination results in the elevation of magnitude of voltage and series combination result in the high value of array current. Arrangements of cell, array and module are shown in the Fig 3.1.



Fig 1. Arrangements of cell, module and array.

3. PV modeling:

The Modelling of PV cell can be done by a and reversed diode with the parallel current source connection. the grouping is characterised with its own parallel and series resistances.

The series resistance has to obtainable due to the difficulty caused by the p-n junction to the flow of electrons where as parallel resistance is cause due to the escape current. When the irradiation falls on the PV cell the creation of electronic field occurs inside the cell. This process of generation of the electric field isolates the positive and negative charge carriers in the absorbing material (adjacent p-n type).

Under the influence of electric field the generated inside the cell by the irradiation the flow of charges in the external circuit results in the flow of current. The amount

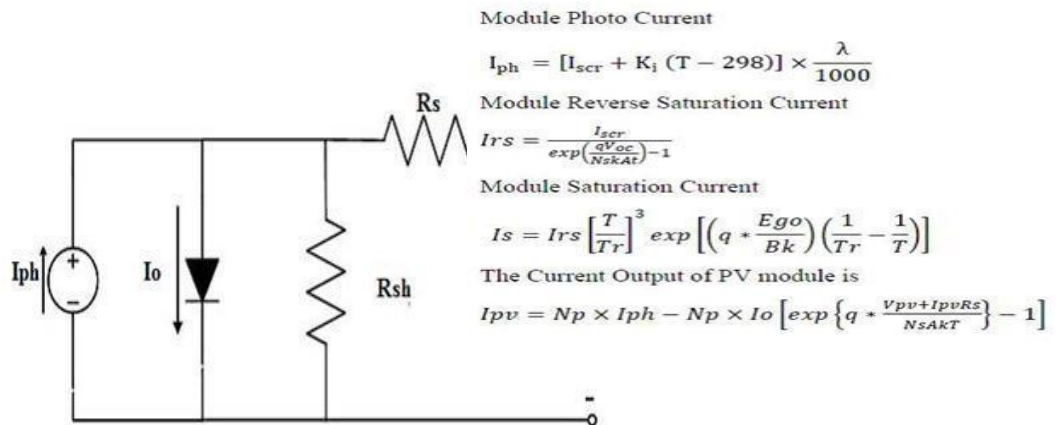

of generated current depends on the amount of the solar irradiation of pv cell. This is the basis why greater current is generated by the greater amount of solar irradiation.

Fig 2. Equivalent PV cell circuit.

Symbols have their standard meaning. I_{ph} - current source.

I_o - diode current.

R_{sh} -parallel resistance. R_s -series resistance. I_{pv} -PV panel current. V_{pv} - PV panel voltage.

The accuracy of the simulation model is very much influenced by the accurate modelling of the PV cell model. Its modelling involves the determine of its I-V and P-V characteristic curve to follow the real cell under existing environmental condition.

Modelling of ideal solar cell possibly will do link the current source in parallel with diode only but since ideal solar cell existence without the series resistance therefore we have to add a series resistance in the form as a shown in figure 3.2. Various type of resistances and current source along with the diode is shown in the figure 3.2.

[12 To achieve the model performance very close model we need to rate the value of resistances such a way that the effect of series resistance neglected. This will result in the simple examination of the circuit.

The symbols are defined as follows,

I_{pv} is output current of a PV module (A)

T_{ris} the reference temperature = 298 K

T is the module operating temperature in Kelvin

I_o is the PV module saturation current (A)

$A = B$ is an ideality factor = 1.6

k is Boltzmann constant = 1.3805×10^{-23} J/K

q is Electron charge = 1.6×10^{-19} C

R_s is the series resistance of a PV module

$$I_{SCr} = 0.0017A / OC$$

E_{g0} is the band gap for silicon = 1.1 eV

Above mentioned equations are implemented in the simulation blocks. By the use of MATLAB integral blocks available in MATLAB library.

4. Characteristic of a PV cell:

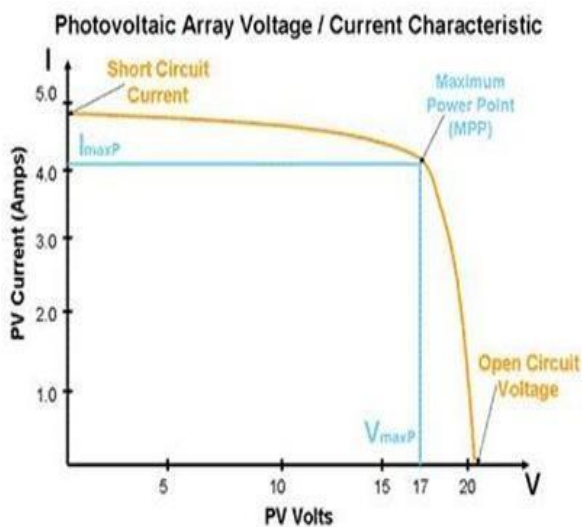

Fig 3. V-I characteristic.

As shown in the fig.3.3 it is clear that the characteristic of a PV cell mainly resolved by three parameters.

- First one is open circuit voltage (V_0).
- Second is short circuit current (I_s)
- Maximum power point (I_{mpp} , V_{mpp}).

The characteristic graph of PV cell itself explains that the maximum powers that can be extracted are at maximum power point. Normally these parameters are to be pre-particular by the producer.

5. Use of Material in PV cell:

Selection of material is an important factor due to its physical and chemical properties which play a deciding role in the performance of the PV cell.

Few frequently used materials are listed below:

- Mono-crystalline Silicon
- Polycrystalline Silicon
- Micro-crystalline Silicon

6. Boost converter:

Main principle of boost converter is to provide step up to the output voltage to the level of 1680V with input voltage of 840V. It is also called as step up converter. It is the collection of (SMPS) switch mode power supply. It consists of fundamentally to semi conductor device diode and transistor.

In the diagram shown below the switch is a MOSFET, BJT or IGBT [12]. The purpose of addition of inductor or a capacitor inductor combination is to decrease the ripple from the power signal. It operates on the high frequency. By operating at high frequency of switches the sufferers can be minimised.

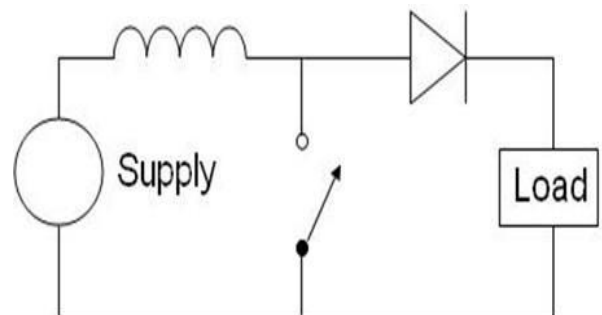

Fig 4. Equivalent circuit of Boost converter.

7. Diesel Generator:

The Diesel generator is used to be the base or peak load have need of generating unit. This base synchronous generator is having the following dimension and parameters. Nominal power/ line-to-line voltage/ frequency

[Pn(VA) Vn(Vrms) fn(Hz)] :: [3.125e6 2400 60] Time

constants [Td' Td'' Tqo''](s):: [3.7, 0.05, 0.05] The value of stator resistance in p.u. is 0.0036.

[H(s) F (pu) p ()]: [1.07 0 2]

Initial conditions is to be set to the value of [dw(%) th(deg) ia,ib,ic(pu)]:

[0 -121.934 0.273926 0.273926 0.273926 -121.89 -

241.89 -1.89045 1.42732]

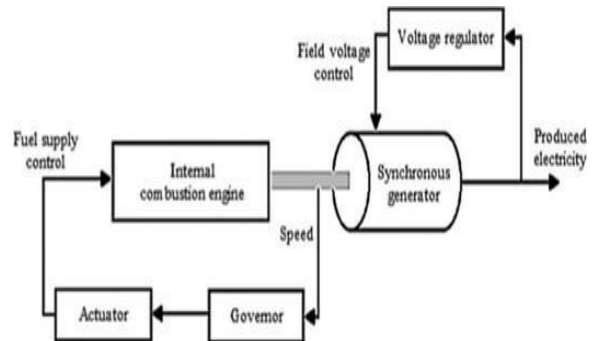

Fig 5. Block Diagram of Diesel Generator.

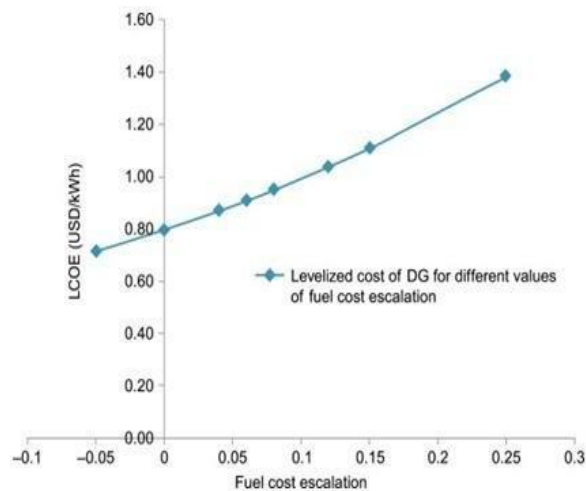

Fig 6. Fuel cost escalation.

8. Implementation of blocks in the simulation:

First of all modelling of PV component is done which is the renewable part of the simulation model. Now this PV module is connected through the grid through the universal bridge. The current received by the universal bridge of the output of boost converter related in between the PV module and universal bridge. Now this output power is feed to the filter to reduce the THD component. With reduced THD component now the power is set to be transfer to the grid after passing through step up transformer. The transformer used in the representation is star-star connected. Just after the transformer a V-I measuring block is added to analyse the output (voltage & current) i.e. now connected to the grid. This grid is already connected to the base diesel power generator with rating of 3.125 MVA.

We need to manage the diesel generator power before feeding it to the main grid and for this purpose a diesel engine speed and voltage control block is added in the simulation of the system block. This block will purpose as the power controller and help in the synchronisation of power

with the grid to which it is connected. The stability of the grid deeply depends upon the synchronisation of the power with generator and the PV module. Thus the accountability of the diesel engine speed & voltage manage block becomes important.

Now this generator isto be connected to the main grid from end to end the three phase breaker of system. Connection of generator through the three phase breaker offers the option of switching in case of sufficient power generation through PV module. It will also help in the testing of power system stability with or withoutof the diesel engine generator.

A three phase V-I measuring block is added to after the generating point of diesel engine for observation purpose. Now further the FFT block and THD analyserthe block is used to analyse the grid power.

IV. AN OVERVIEW OF FUZZY LOGIC& PQ CONTROL METHOD

Fuzzy logic exhibits success in the wide range of application that has attracted the interest of graduate students, academic professionals and engineers.

This chapter focuses on the aspects of theory that serve as the basis for fuzzy logic based control & classification of model.The term fuzzy logic has to be used for two diverse right minds. It refers to the two valued analysis under indecision. Technically we can say that it refers to the all theories that hold non discrete boundaries.

1. History:

The idea about fuzzy set roughly July 1964 evolved. Lofti

A. Zardan a renoundthe professor at university of California Berkeley, the idea of partisanship purpose later on which became the back of fuzzy set theory he developed. Despite of strong resistance to the idea of fuzzy set theory he continuous his research work in this field. Other extraordinary contributions were made by

R.E Bellan's work with fuzzymultistage decision making. G.Lakoff's work from linguistic view, R.E. Smith and M.Sugeno worked on fuzzy measures. In the early decade of its evolution fuzzy logic research suffered from civilizing Revolution in many part of the world.

In the year 1976 first fuzzy logic application came in the subsistence. The acknowledgment goes to the Blue Circle Cement and SIRA in Denmark country.They intended a system for the control of residue for smooth grinding. . After the application in two separate areas now the Japanese scientist used the fuzzy logic for water conduct plant control.

In this way the boom of fuzzy logic took place in the Japan with the co-operation of industries and universities in the circuits.

2. Basic concept of Fuzzy logic

Fuzzy logic exhibits four core concepts:

2.1 Fuzzy sets: This is sets with the non-discrete boundaries

2.2 Linguistic Variable: Variable with values of that can have both quantitative as well as qualitative method illustrated by the Fuzzy set.

2.3 Possibility distribution: This concept is used in assigning restrain of the linguistic variable that is illustrated in the Fuzzy set.

3. Designing of Membership function:

First of all the importance of the Membership occupation should be known while in action with Fuzzy set rule. As basic feature of Fuzzy set with even boundaries membership function (MF) provide regular transition from external region to the district lying completely inside. Fuzzy rule based inference:

Rule based conclusion of Fuzzy consist of three critical steps and one optional step:

3.1 Fuzzy matching: Degree of comparable of data with Fuzzy rule based situation.

3.2 Inference: Conclusion based on identical degree is calculated.

3.3 Combination: according to the Fuzzy rule based close is collective.

3.4 Defuzzification: There are many systems where the ending output is needed hard one. This step of generate a final breakable output is Defuzzification.

4. Fuzzy If and Then rule:

We can say that this rule is nothing but a method to collect knowledge that involves haziness. Basically it is of two types:

- Fuzzy mapping rule
- Fuzzy implication rule

For the control purpose the fuzzy If and Then rule is developed.

The set of rules are given below:

If (ERROR is NB) and (CERROR is NB) then (DN is ZE) If (ERROR is NB) and (CERROR is NS) then (DN is ZE) If (ERROR is NB) and (CERROR is ZE) then (DN is PB) If (ERROR is NB) and (CERROR is PS) then (DN is PB) If (ERROR is ZE) and (CERROR is NB) then (DN is PS) If (ERROR is ZE) and (CERROR is NS) then (DN is ZE) If (ERROR is ZE) and (CERROR is ZE) then (DN is ZE) If (ERROR is ZE) and (CERROR is PS) then (DN is ZE) If (ERROR is ZE) and (CERROR is PB) then (DN is NS) If (ERROR is PS) and (CERROR is NB) then (DN is NS) If (ERROR is PS) and (CERROR is NS) then (DN is NS) If (ERROR is PS) and (CERROR is ZE) then (DN is NS) If (ERROR is PS) and (CERROR is PS) then (DN is ZE) If (ERROR is PS) and (CERROR is PB) then (DN is ZE) If (ERROR is PB) and (CERROR is NB) then (DN is NB) If (ERROR is PB) and (CERROR is NS) then (DN is NB) If (ERROR is PB) and (CERROR is ZE) then (DN is NB) If (ERROR is PB) and (CERROR is PS) then (DN is ZE) If (ERROR is PB) and (CERROR is PB) then (DN is ZE)

On the basis of these system generated during the fuzzy controller.

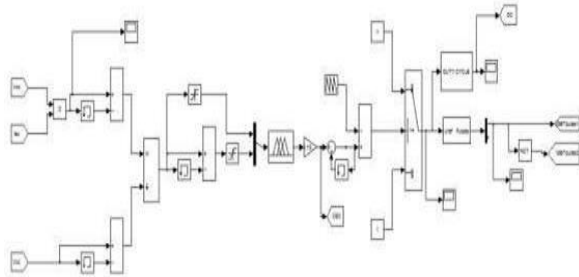

Fig 7. Fuzzy controller block diagram.

Membership function of the Error intended the rule-based rule is shown below.

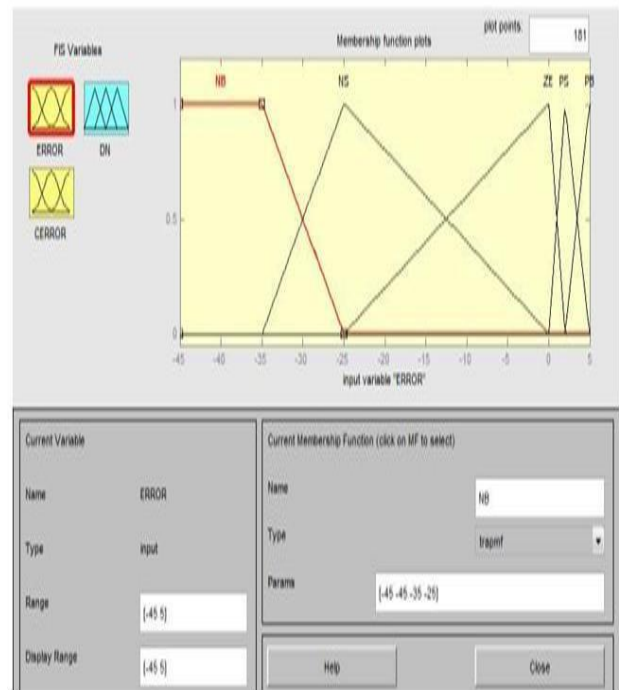

Fig 8. MF of the Error designed rule-based rule.

Error as input with a choice of [-45,5]. It can be seen from the figure that the membership function NB is a maketrapezium function.

Membership function of the modify in Error to be calculated rule-based rule is shown below.

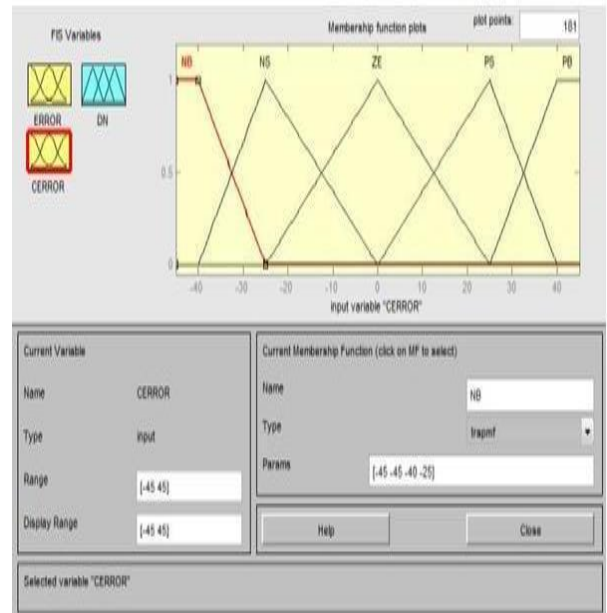

Fig 9. MF of the change in Error designed rule-based rule. Membership function of output designed to the rule-based rule is shown below.

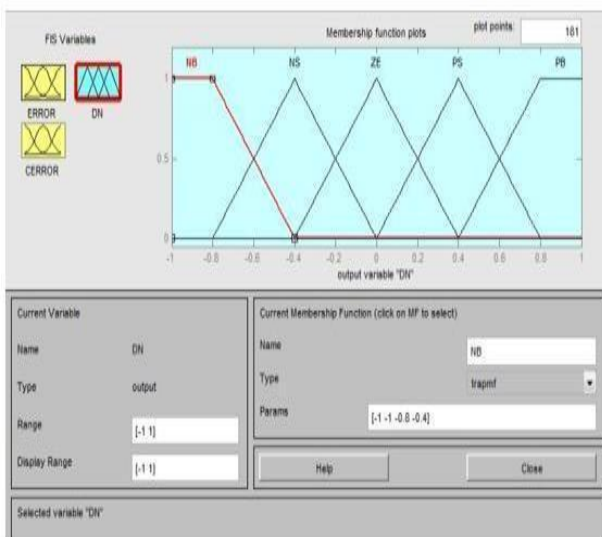

Fig 10. MF of output designed rule-based rule.

5. PQ controller:

It operates on the basic model of controlling active and reactive power during generator side and grid side respectively. Manners of full power converter. Satisfactory control of diesel generator

during this method is performed in the simulation.

V. SIMULATION, RESULTS AND ANALYSIS

The Simulation Design with unlike machinery is implemented in the MATLAB. Power system with high PV penetration exists originally.

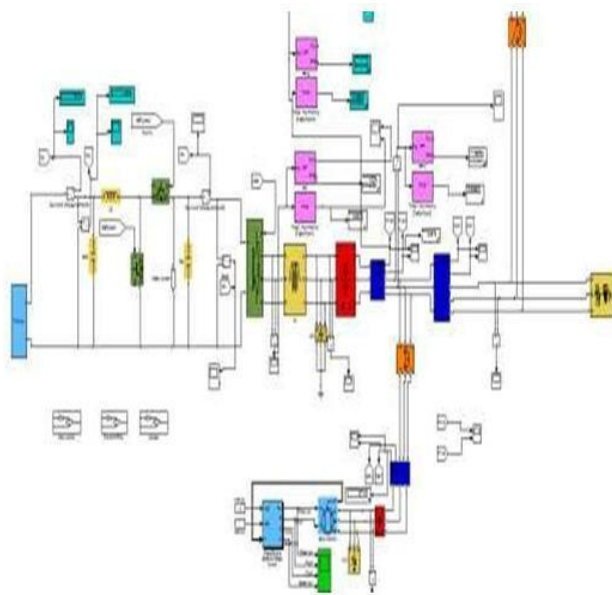

Fig 11. Simulation model.

In this simulation model power output from end to end the PV panel is kept continuous while the diesel producer is connected to the grid and remote from the grid at pre- specified direct with the help of breakers.As we are integrating a renewable source of energy to the main grid connection and its isolated condition collision is analysedthoroughly. We are using PQ control for the diesel generator and Fuzzy logic the control for PV panel.

1. Result 1:

The Output voltage when connected to the load.

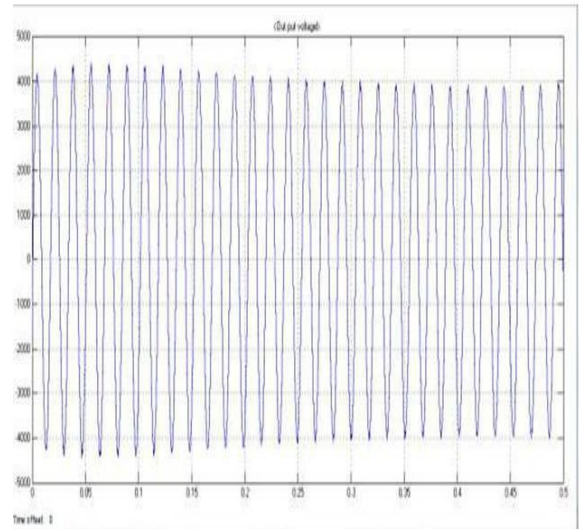

Fig 12. PV Voltage output.

The value of peak voltage of the output is very close to calculated value of the voltage. It can be seen from the output graph that the magnitude and variation of output voltage is to be constant. It can be observed that in the graph of the output that when the PV panel is started the supply of power to the load initially the output of the voltage shoot slightly upward and after the time of 0.15 seconds it attains the stable value. At this instant of the PV panel is only accountable for the supply of power to the load.

This condition is analysed because of the motive that the locations where only PV module is enough enough for load requirement. In case of any exploring centres within the dessert area where the load is occasional. In such a condition only PV generated power will be able to get together the load demand. This investigation shows the possibility of isolated PV generation plant.

2. Result 2: Harmonic analysis:

Peak Magnitude harmonics analysis of only PV connected to load. After the harmonic analysis of inaccessible system the harmonics are not in the range of international standard. So filter is functional to reduce the THD module.

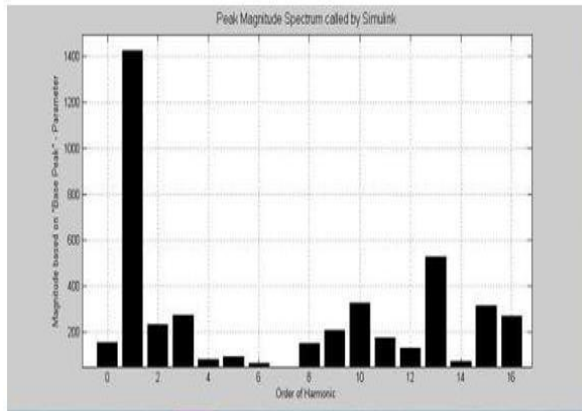

Fig 13. PV Harmonic output before filter.

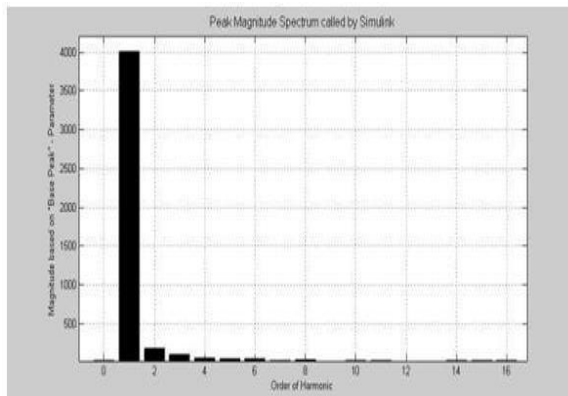

Fig 14. PV Harmonic output after filter.

After the inference of filter the THD component of system is found in the range of allowable international limits. Now after the remote analysis we are going to connect the Diesel generator and further the stability and THD component will to be analysed. Most of the location requires greater supply of electric energy.

Photovoltaic generation system in such a condition can be used as peak load order generation. Storage of energy with the help of batteries can also be done during day time when the efficiency of solar generating unit is high due to the high solar irradiation.

3. Result 3: Voltage output after calculation of Diesel generator with PV panel.

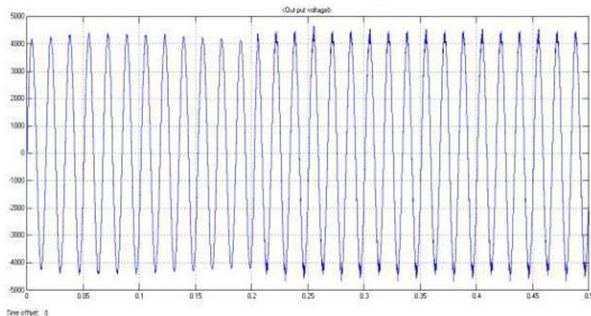

Fig 15. PV+D Voltage output.

When the Diesel generator is added to the power system at the instantaneous of .2 second the slight shoot in the voltage peak is observed.

The THD components were high. Before the filter it has a figure of 69.61%.

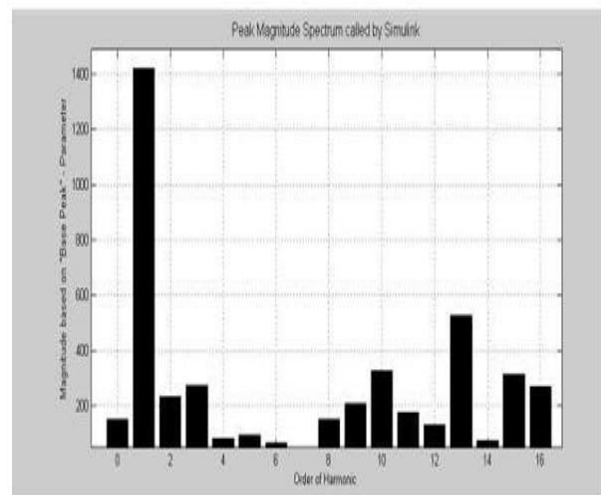

Fig 16. PV+D Harmonic output before filter.

After the implementation of clean its spectrum is reduced to 3.594%. As shown below in Fig

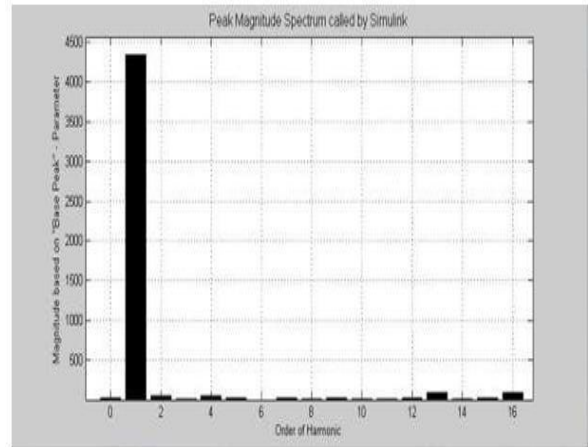

Fig 17. PV+D Harmonic output after filter.

The Harmonics analysis with the variation in the voltage of the system is satisfactory till now.

Above investigation was done as the independent power generation and supply to be the local series RLC load.

4. Result 4: Now the diesel generator all along with the PV power generating unit is incorporated to the grid at the immediate of .3 second from the start of the simulation.

This was the main expression to maintain the permanence of the power system.

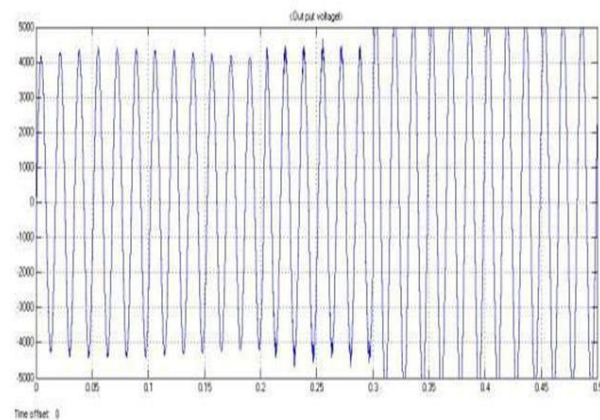

Fig 18. PV+DG +Voltage output.

Harmonic analysis before the filter and after the filter in the entirely integrated system is finally done. As per the output twisted in the simulation following graph is plotted.

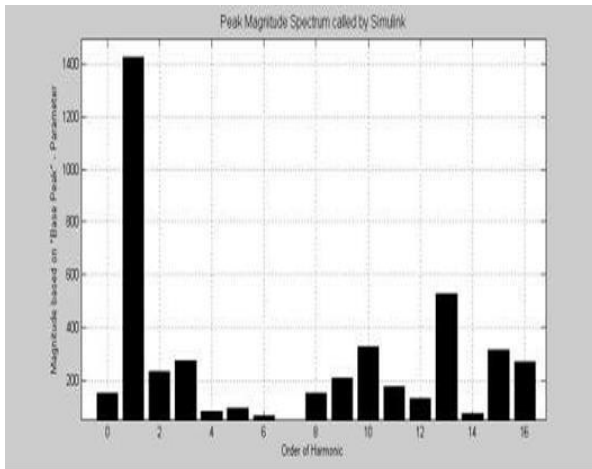

Fig 19. PV+D+G Harmonic output before filter.

Above mention graphis shown in fig 5.8 represents the harmonic mechanism of the output voltage before the filter.The result shown is not in acceptable value oflimits.Finally after the application of filter the output voltage spectrum came into the picture acceptable limit.

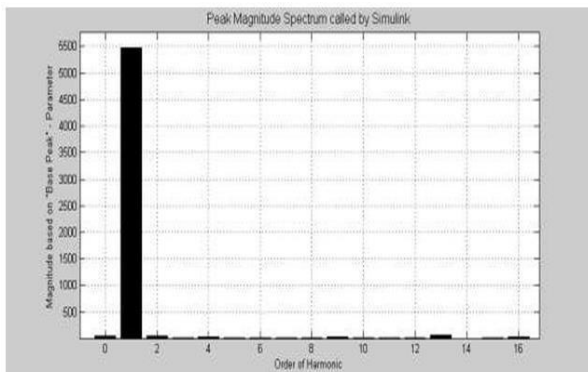

Fig 20. PV+D+G Harmonic output after filter.

This is the final output of voltage field with acceptable THD section. This simulation shows that the co-ordinatedPQ &Fuzzy logic control to can be successfully implemented.

VI. CONCLUSION

In the present state the Electricity has become the driving force of all key factors that is having most important impact in the life of mankind. Even the principle for developed country or budding countryreports the electricity consumption per capita.In the last few decades the rapidity of demand of electricity & its generation does not match the transmission system. So there is huge overcrowding in the transmission system presently. That is the reason now a day incorporation of

renewable source of energy with the grid close to the location of load. Initially the control process in coordination was PQ and VF organizes for better response time Fuzzy is replaced with VF. Tuning of filter with THD is listed below.

Table 1. Tuning value of inductor.

S. No.	Parameter(L)	Peak Voltage OUTPUT	Thd(%)
1	70 μ H	4000	26.98
2	700 μ H	444	17.92
3	7 μ H	394	48.41

In this project combination of PV panel is successfully done with the breathing grid as well as with the isolated load system. In the first part of simulation the analysis of voltage and its THD module is done without grid combination. In the second part of the simulation integration with the diesel generator is completed and various components along with THD satisfied is analysed. In the third and final part the addition of PV and diesel generator with grid is complete. The analysis and possibility of integrated system is checked and the THD analysis is summarised in table 6.1. Table 2. Harmonic content.

SNO	Harmonics before filter	Harmonics after filter
PV	69.54	4.713
PV+ D	69.61	3.594
PV+ D+G	69.55	1.839

REFERENCES

- [1] Modeling and Power Quality study of Integrated Renewable Energy System Rinchin W. MosobiTokoChichiSarsingGaoDepartment of Electrical Engineering, North Eastern Regional Institute of Science and Technology, Nirjuli, Arunachal Pradesh
- [2] Real and Reactive Power Control of a Three- PhaseSingle-Stage PV System and PV Voltage StabilityHuijuan Li, Member, IEEE; Yan Xu, Senior Member, IEEE; SarinaAdhikari, Student Member,IEEE; D. Tom Rizy, Senior Member, Fangxing Li, Senior Member, IEEE; Philip Irminger, StudentMember, IEEE
- [3] Distributed Adaptive Voltage Controlof Inverter- Based MicrogridsAli Bidram, Student Member, IEEE, Ali Davoudi, Member, IEEE, Frank L. Lewis, Fellow, IEEE, and Shuzhi Sam Ge, Fellow, IEEE
- [4] N. Altin, I.Sefa, "dSPACE based adaptive neuro- fuzzy controller of gridinteractive inverter," Energy Conv. Manag., vol.56, pp.130-139, April 2012.
- [5] E.H. Mamdani, "Application of fuzzy algorithms for control of a simple dynamic plant," IEEE Proc. D. vol. 121, pp. 1585-1588, December 1974.
- [6] A. Messai, A. Mellit, A. M. Paavan, A. Guessoum, H.Mekki, "FPGA based implementation of a fuzzy controller (MPPT) for photovoltaic module," Energy Conv.Manag. vol. 52, pp. 2695-2704, July 2011.